



P61089SDM

Dual Programmable Thyristor Transient Voltage Suppressor

版本号
202207-A

Description

This device has been especially designed to protect 2 new high voltage, as well as classical SLICs, against transient overvoltages. Positive overvoltages are clamped by 2 diodes. Negative surges are suppressed by 2 thyristors, their breakdown voltage being referenced to $-V_{BAT}$ through the gate. This component presents a very low gate triggering current in order to reduce the current consumption on printed circuit board the firing phase. These devices are not subject to aging and provide a fail safe mode in short circuit for a better protection. Pic 1 and pic 2 are the device symbol and the package.

Features and Benefits

- Dual Voltage-Tracking Protectors
- wide negative pressure range: $V_{MGL} = -167V_{MAX}$
- low dynamic switching voltage: V_{FP} and V_{DGL}
- low gate triggering current: $I_{GT} = 6mA_{Max}$
- Peak Pulse Current: $I_{PP} = 150A$ (10/700 μs)
- high Holding current: $I_H \geq 120mA$

Application field

P61089SDM are designed to protect communication equipment such as SPC exchanger from damaging overvoltage transients in the second level.

Characteristic parameters

symbol	Rated value	unit
V_{MGL}	-167	V
$I_{PP}(10/700\mu s)$	150	A
I_H	120	mA

Package :SOP-8

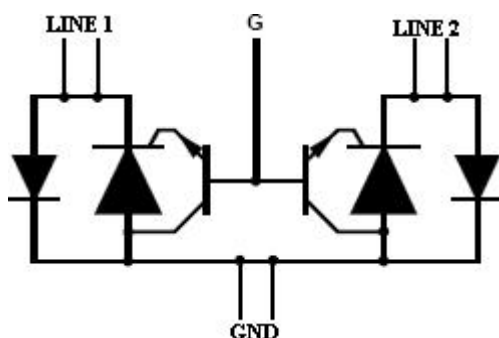

Pic.1 Device equivalent structure

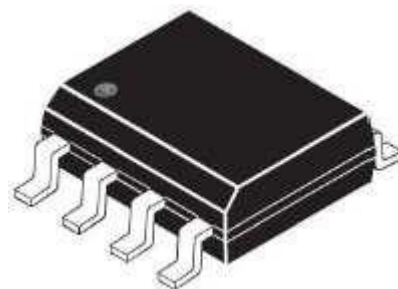

Pic.2 Device type SOP-8



Electrical Parameters

Standard

type	Wave shape		ITSP
ITU-T K.20/21andK.45	voltage	10/700us	150A
	current	5/310μs	

Electrical characteristics

- Absolute maximum ratings $T_a = 25^\circ\text{C}$ unless otherwise noted

symbol	parameters	value	unit
V_{PP}/I_{PP}	Peak pulse voltage /current (tip.1)	10/700μs	6000
		5/310μs	150
I_{TSM}	Non repetitive peak pulse Current(F=60Hz)	$t_p=500\text{ms}$	6.5
		$t=1\text{s}$	4.6
I_{GSM}	Maximum gate current (half sinusoid $t_p=10\text{ms}$)	2	A
V_{MLG}	Line-ground maximum voltage	-170	V
V_{MGL}	Gate-line maximum voltage	-167	V
T_{stg}	Storage Temperature Range	-55~150	$^\circ\text{C}$
T_j	maximum temperature	150	$^\circ\text{C}$
T_L	maximum sustainable temperature of solder in 10 seconds	260	$^\circ\text{C}$

tip.1: pulse form:
5/310μs $t_r=5\mu\text{s}$ $t_p=310\mu\text{s}$ 100% I_{PP}

- V-I characteristic curve ($T_a = 25^\circ\text{C}$)

symbol	parameters
I_{GT}	Gate trigger current
I_H	Holding current
I_{RM}	Line-ground reverse leakage current
I_{RG}	Gate-line reverse leakage current
V_{RM}	Line-ground reverse voltage
V_F	Line-ground voltage
V_{GT}	gate trigger voltage
V_{FP}	Line-ground peak voltage
V_{DGL}	Gate-line dynamic switching voltage
V_{GATE}	Gate-ground voltage
V_{LG}	Line-ground voltage
C	Line-ground off state capacitance

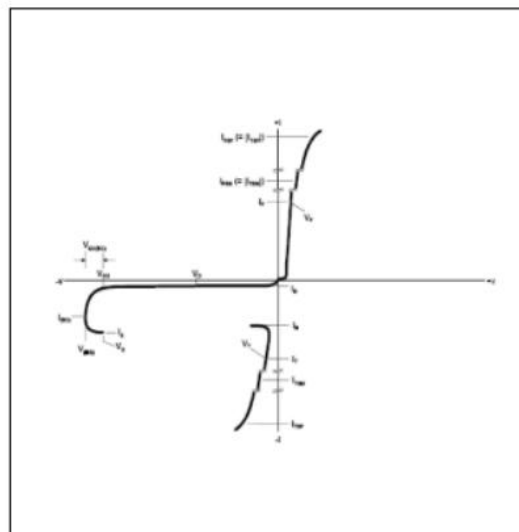
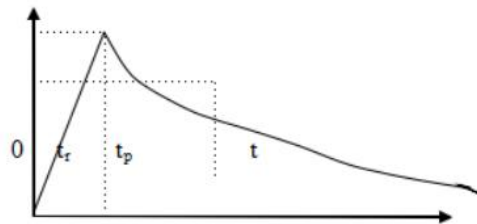



Electrical Parameters

Absolute maximum ratings $T_a = 25^\circ\text{C}$ unless otherwise noted

● Line-ground diode parameters

symbol	Test conditions	Max.	unit
V_F	$I_F=5\text{A}$, $t_p=500\mu\text{s}$	3	V
V_{FP}	10/700 μs 1.5kV $R_P=10\Omega$ (tip. 1)	5	V

tip.1 $\diamond V_{FP}$ refers to test circuit 2, R_P is the protective resistance mounted on the card

● thyristor parameters($T_a=25^\circ\text{C}$)

symbol	Test conditions	Min.	Max.	unit
I_{GT}	$V_{GND}/LINE=-100\text{V}$	0.1	6	mA
I_H	$V_{GATE}=-100\text{V}$	150		mA
V_{GT}	Same to I_{GT}		2.5	V
I_{RG}	$T_C=25^\circ\text{C}$ $V_{RG}=-170\text{V}$		5	μA
	$T_C=70^\circ\text{C}$ $V_{RG}=-170\text{V}$		50	
V_{DGL}	$V_{GATE}=-100\text{V}$ (TIP.3) 10/700 μs 1.5kV $R_P=10\Omega$		10	V

Tip.2:see holding current (I_H)at test circuit 2;

Tip.3:see V_{DGL} at test circuit 1, Don't make records if fluctuation time is less than 50ns.

● thyristor and diode parameters

Symbol	Test conditions	Max.	unit
I_{RM}	$T_C=25^\circ\text{C}$ $V_{GATE}/LINE=-1\text{V}$ $V_{RM}=-167$	5	μA
	$T_C=70^\circ\text{C}$ $V_{GATE}/LINE=-1\text{V}$ $V_{RM}=-167$	50	μA
C	$V_R=-3\text{V}$ $F=150\text{KHZ}$	100	pF
	$V_R=-48\text{V}$ $F=150\text{KHZ}$	50	pF

● Attention

For eliminate the overvoltage from the line
Parasitic induction,especially at the high speed
and short moment signal, we make
TIP and RING across the device.

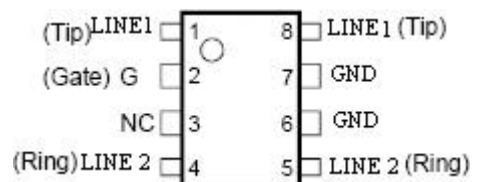

■ Test method and circuit

- Holding current test circuit(test circuit1)

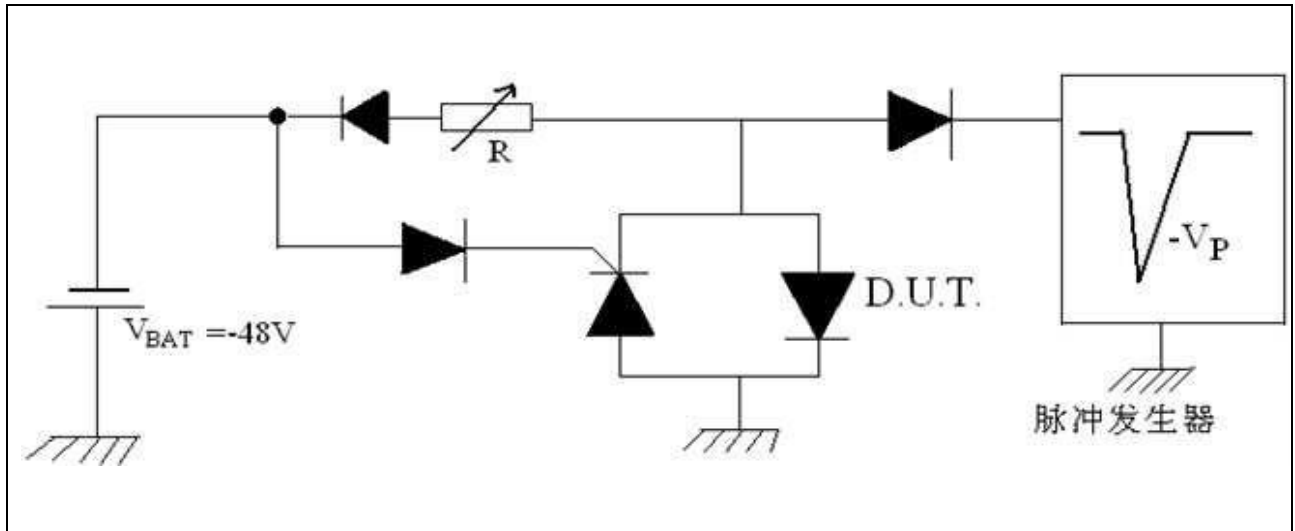

This is a “Conducting-cutoff” test. The test circuit can ascertain the size of holding current.

Test method :

- ① short out DUT , regulating current in I_H range;
 - ② set $I_{PP}=10A$, 10/1000 μs surge current triggers DUT;
 - ③ DUT must return to the off-state in 50ms.and
- V_{FP} and V_{DGL} test circuit2

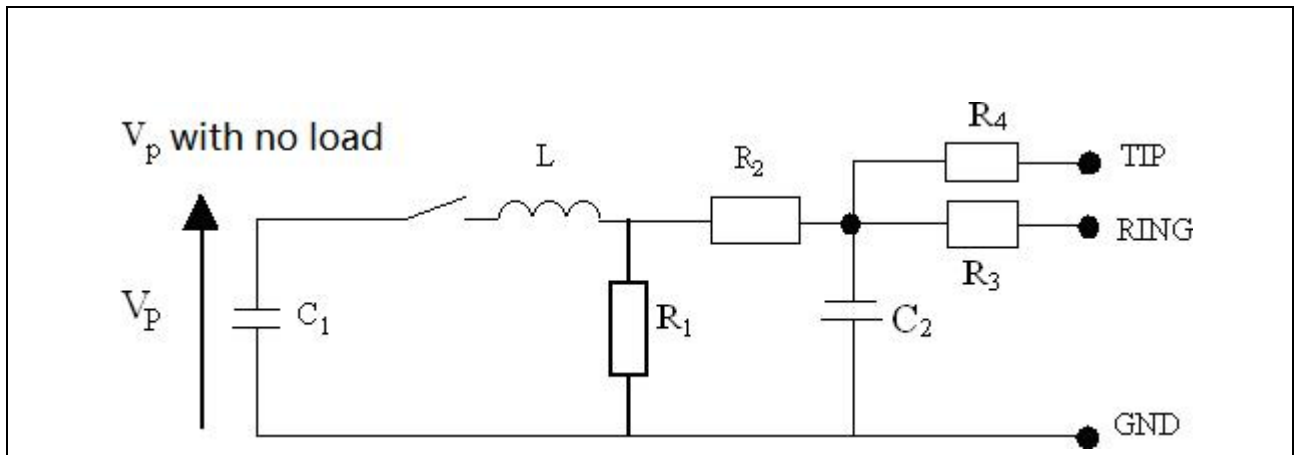

Plue(us)		V_P (V)	C_1 (μF)	C_2 (μF)	L (μH)	R_1 (Ω)	R_2 (Ω)	R_3 (Ω)	R_4 (Ω)	I_{PP} (A)	R_P (Ω)
t_r	t_p										
10	700	1500	20	200	0	50	15	25	25	30	10
1.2	50	1500	1	33	0	76	13	25	25	30	10
2	10	2500	10	0	1.1	1.3	0	3	3	38	62

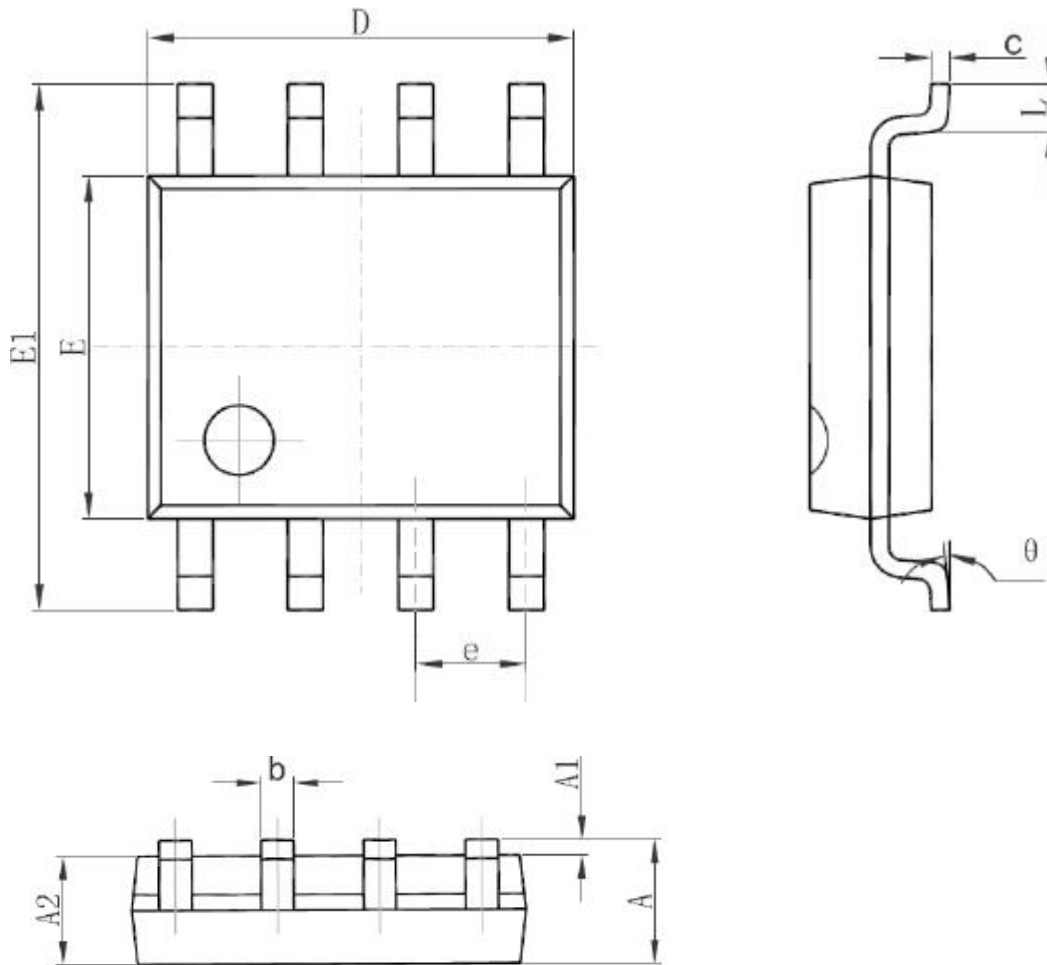
**Package size****■ Appearance size SOP-8**

Symbol	Dimensions In Millimeters		Dimensions In Inches	
	Min	Max	Min	Max
A	1.350	1.750	0.053	0.069
A1	0.100	0.250	0.004	0.010
A2	1.350	1.550	0.053	0.061
b	0.330	0.510	0.013	0.020
c	0.170	0.250	0.006	0.010
D	4.700	5.100	0.185	0.200
E	3.800	4.000	0.150	0.157
E1	5.800	6.200	0.228	0.244
e	1.270(BSC)		0.050(BSC)	
L	0.400	1.270	0.016	0.050
θ	0°	8°	0°	8°

Marking



Naming Rule

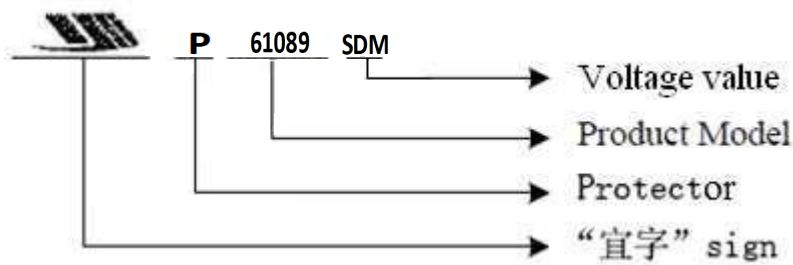

XXYY:XX means year, YY means week.

Package Information

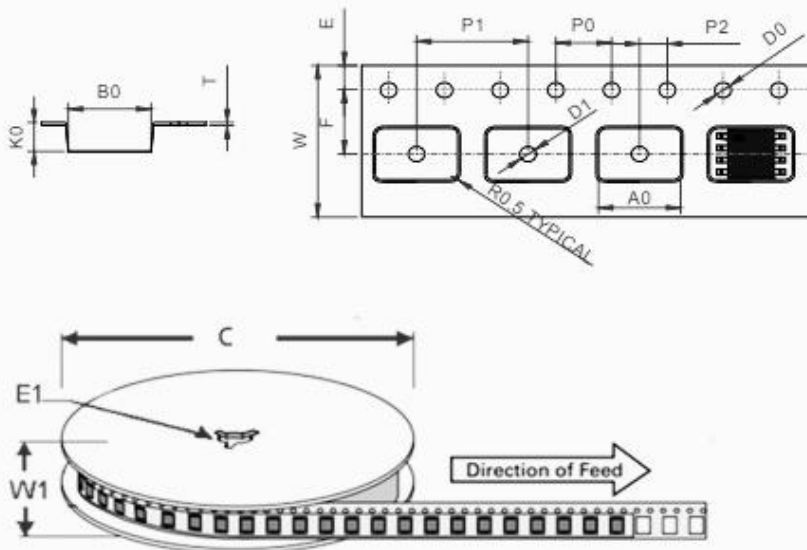

Ref.	Dimensions	
	Millimeters	Inches
A0	6.6±0.10	0.260 ± 0.004
B0	5.3±0.10	0.209 ± 0.004
C	330	13.0
D0	1.50±0.10	0.059 + 0.004
D1	1.50±0.10	0.059 + 0.004
E1	13.3±0.3	0.524± 0.012
E	1.75±0.1	0.069 ± 0.004
F	5.5±0.05	0.217 ± 0.002
K0	2.1±0.1	0.083 ± 0.004
P0	4.0±0.1	0.157± 0.004
P1	8.0±0.1	0.315± 0.004
P2	2.0±0.05	0.079 ± 0.002
T	0.24±0.1	0.009 ± 0.002
W	12.0±0.3	0.472 ± 0.012
W1	15.7±2.0	0.618 ± 0.079

Package Type	Quantity
SOP-8	4000



NOTICE

The purchased products, services and features are stipulated by the contract made between Dongchen Incorporated and the customer. All or part of the products, services and features described in this document may not be within the purchase scope or the usage scope. Unless otherwise specified in the contract, all statements, information, and recommendations in this document are provided "AS IS" without warranties, guarantees or representations of any kind, either express or implied.

The information in this document is subject to change without notice. Every effort has been made in the preparation of this document to ensure accuracy of the contents, but all statements, information, and recommendations in this document do not constitute a warranty of any kind, express or implied.

